



# LORAWAN BUTTON SMART-WB0101

USER MANUAL



DOCUMENT REVISION	DEVICE REVISION	FIRMWARE VERSION
02	1	2.0 EU

## CONTENTS

INTRODUCTION.....	3
1 DEVICE PURPOSE AND OPERATION PRINCIPAL.....	4
DEVICE PURPOSE.....	4
OPERATION ALGORITHM .....	4
FSK RADIOCHANNEL.....	6
FUNCTIONAL.....	7
MARKING.....	7
2 SPECIFICATION.....	8
DEVICE SPECIFICATION.....	8
DEFAULT DEVICE SETTINGS .....	9
3 OPERATION.....	10
DEVICE APPEARANCE.....	10
INDICATION .....	11
Button MOUNTING RECOMMENDATIONS.....	12
4 COMMUNICATION PROTOCOL – 2.0 VERSION.....	14
SMART-WB0101 transmits the following types of packets.....	14
SMART-WB0101 receives THE FOLLOWING TYPES OF PACKETS.....	15
5 STORAGE AND TRANSPORTATION REQUIREMENTS .....	17
6 CONTENT OF THE PACKAGE.....	18
7 WARRANTY .....	19

## INTRODUCTION

This manual is designated for Vega Smart-WB0101 wireless autonomous LoRaWAN® button (hereinafter – device, button) manufactured by Vega-Absolute OOO and provides information on powering and activation procedure, control commands and functions of the device.

This manual is targeted at specialists familiar with installation work fundamentals for electronic and electrical equipment.

Vega-Absolute OOO reserves the right to make changes to the manual related to the improvement of equipment and software, as well as to eliminate typos and inaccuracies, without prior notice.

# 1 DEVICE PURPOSE AND OPERATION PRINCIPAL

## DEVICE PURPOSE

The Vega Smart-WB0101 button is designed to notify the Personnel about the User pressing. Main purpose of the button is to call the Personnel - hotel staff, a waiter in a restaurant, medical staff, a warehouse employee etc. Another possible use case is calling emergency services, building rapid response systems in Smart Cities.

The device is powered by two AAA type batteries.



**The device is powered by a non-rechargeable alkaline type AAA batteries  
Attempts to charge the battery may result in fire**

## OPERATION ALGORITHM

Vega Smart-WB0101 operates in modes listed below:

**"Storage"** – is a mode for storing and transporting. In this mode the device does not communicate regularly with the network.

**"Active"** – is a main mode of device operation.

Initially, the device is not connected to power, because the batteries are not inserted into the appropriate slots in the device. Batteries must be installed before operation.

Vega Smart-WB0101 supports two activation methods in the LoRaWAN® network - ABP and OTAA. Select one of the methods via the "Vega LoRaWAN Configurator" application (see "User Manual" on the program).

**ABP method.** After inserting the batteries, the device immediately starts working in the "Active" mode.

**OTAA method.** After inserting the batteries, the device makes three attempts to connect to the network within the set frequency plan. After the activation in the LoRaWAN® network is confirmed, the device sends a signal and switches to the "Active" mode. If all attempts fail, the device will continue to accumulate data and will attempt to connect to the network every 6 hours.

In the "Active" mode there are 5 possible states.

**"Waiting" (01).** In this state, the button communicates according to the schedule, displays an indication - a green flash once every 30 seconds. When switching from any state to state 01, the device displays 2 green flashes in a row as an indication.

In this state, the transmission period can be set from 5 minutes to 24 hours. The data is stored in the device memory and transmitted during the next communication session with the LoRaWAN® network. Data transfer is carried out at a random time within the selected period.

"Alarm transmission" (02) state is initiated after a short press on the button. Pressing the button for less than 10 seconds initiates the sending of the "Alarm transmission" packet to the Server in a customizable mode – every 3...99 seconds for 5 minutes, then according to the algorithm for reducing the frequency of data transmission and the transition to state 02, indicated by frequent continuous flashing of the red LED.

The button switches to the "Alarm received" (03) state after receiving confirmation of the delivery of the alarm message to the Server. At the same time, the device continues to send alarm messages once every 2 minutes for an hour, and then lower the frequency according to the algorithm. The indication in the "Alarm received" state is short flashes of the red LED every 2 seconds.

The device switches from the states (02) and (03) to the "Alarm cancellation" (04) state when the button is pressed and held for 0...25 seconds (set by the User). In this case, the device continues to send messages every 10 seconds for 5 minutes, after which it enters state (01). In this case, the indication changes to double green flashes when sending each message.

The device switches to the state "Alarm accepted by the operator" (05) after receiving confirmation that the alarm has been accepted into operation. At the same time, the device changes its indication to a continuous glow of the red LED, continues to send alarm messages once every 2 minutes for an hour, and then lowers the frequency according to the algorithm.

"Idle" state (06) When the Idle sending mode is enabled, pressing the button sends a single packet with operation mode 06 to the Server. At all other times, the device remains in the "Waiting" state (01).



The decrease in the frequency of data transmission is carried out in accordance with the algorithm until the transmission period becomes equal to that set for the state (01) "Waiting". In this case, further reduction is not carried out.

Segment 5...60 minutes – message transmission every 2 minutes

Segment 1...3 hours – message transmission every 5 minutes

Segment 3...6 hours – message transmission every 15 minutes

Segment 6...12 hours – message transmission every 30 minutes

Segment 12...24 hours – message transmission every 60 minutes

After 24 hours, send messages according to the schedule set for state (01).

When the battery charge drops to 10%, the device changes its indication to a flashing red LED every 30 seconds and every hour adds a low battery message to the black box to be sent to the Server.

Up to 200 messages can be stored in the black box of the device. If the message has not been sent, it is stored in a black box until the next scheduled or alarm communication session. Messages are sent on a FIFO basis. The exception is alarm messages - they have priority and are sent without a queue.

With the "Confirmed uplinks" option turned on, the device will send the next packet only after receiving a confirmation of the delivery of the previous one. If such confirmation have not received after the fulfilled in the settings uplink number of transmission, device completes the communication session until the next one according to the schedule. In this case, the device continues to collect data according to the data collection period and store it in memory. Non-transmitted packets remain in the device memory until the next communication session.

With the "Confirmed uplinks" option turned off, the device just sends all accumulated packets to the network in order from the earliest to the latest. There are no checks of package delivery in this mode. There are no non-transmitted messages in the device memory.

The internal clock is set automatically when device connected to the "Vega LoRaWAN Configurator" via USB, also adjustable via LoRaWAN®.

## FSK RADIOCHANNEL

For a local wireless connection to a personal computer, the device implements switching between LoRa and FSK modulation modes, that means an FSK radio channel.

To organize such a connection, an additional device "Vega FSK Dongle" is used, which is connected to the USB port of the computer.

To read and change device parameters, the "Vega LoRaWAN Configurator" program is used.

The FSK radio channel allows you to organize a local wireless (up to several tens of meters) connection to the device for reading and changing its parameters.

To connect via FSK you will need:

- ⦿ "Vega FSK Dongle" device connected to the USB port of a personal computer.
- ⦿ FSK key, which is individual for each device and is available upon request, along with identification numbers and keys of the LoRaWAN® network.

## FUNCTIONAL

Vega Smart-WB0101 motion sensor is class A device (LoRaWAN® classification) and has the following features:

- ⦿ ADR support (Adaptive Data Rate)
- ⦿ Sending of confirmed packets (configurable)
- ⦿ Sending an alarm packet when a button is pressed
- ⦿ Battery charge measurement (%)

## MARKING

Device marked with **sticker** that contains the following information:

- ⦿ Device model;
- ⦿ DevEUI;
- ⦿ Month and year of manufacture;
- ⦿ Certification marks.

**Sticker located in three places** – on device case, in factory certificate and on the packing box.

Besides, there is an additional sticker located on the packing box and contains:

- ⦿ Information about firmware version;
- ⦿ QR code containing device activation keys in the LoRaWAN® network, production date and other identifiers.

## 2 SPECIFICATION

### DEVICE SPECIFICATION

MAIN	
Interfaces	UART, FSK
Operating temperatures	0...+50 °C
LORAWAN®	
LoRaWAN® class	A
Quantity of LoRaWAN® channels	16
Frequency plans supported by default	RU868, EU868, KZ865, custom (EU868 based)
Frequency plans available as order option	IN865, AS923, AU915, KR920, US915
Activation type	ABP or OTAA
Communication period	5, 15, 30 minutes, 1, 6, 12 or 24 hours
Memory amount for storing packets	200 packets
LoRaWAN® antenna type	internal
Sensitivity	-138 dBm
Radio coverage in restrained urban conditions	max 5 km
Radio coverage within line of sight	max 15 km
Transmitter power by default	25 mW (configurable)
POWER	
Replaceable battery	2 x AAA
Estimated number of packets sent by the device at default settings, not less	15 000
CASE	
Housing dimensions	76 x 76 x 20 mm
Ingress protection rating	IP20

## DEFAULT DEVICE SETTINGS

PARAMETER	VALUE
Frequency plan	RU868
Activation type	OTAA
Adaptive Data Rate	ON
Confirmed Uplinks	OFF
Rx 1 Delay	1 second
Join Accept Delay	5 seconds
Uplink number of transmissions	1
Data rate	DR0
Power	25mW (14 dBm)
Time to determine a long press on the button, s	10
Period of sending alarm messages, s	10
Communication period	24 hours
Data collection period	24 hours
Time zone	UTC +00:00

For changing the device settings, you need to connect to it with “Vega LoRaWAN Configurator” application. You can download app on the [iotvega.com](https://iotvega.com) site in SOFT section as well as User Manual for configurator. [Go to the app page.](#)

### 3 OPERATION

#### DEVICE APPEARANCE

The Vega Smart-WB0101 device is presented in a small plastic case with a possibility to mount with two-sided adhesive tape.



1 – LED indicator

2 – pressing area

Contacts for connection are located inside the case on the board.

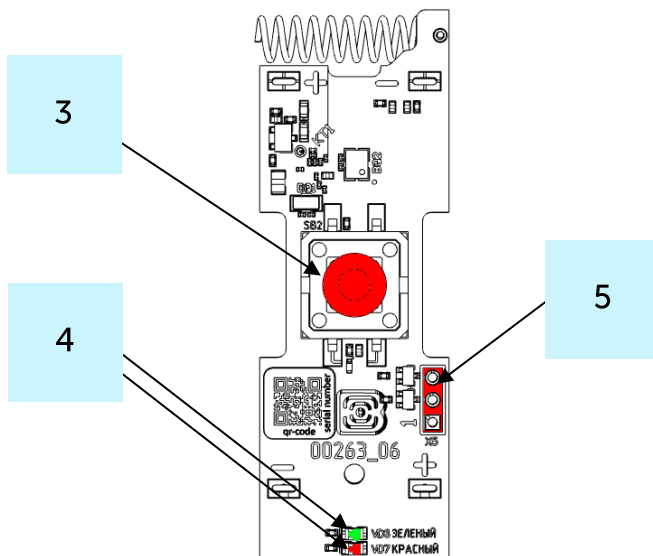

3– button







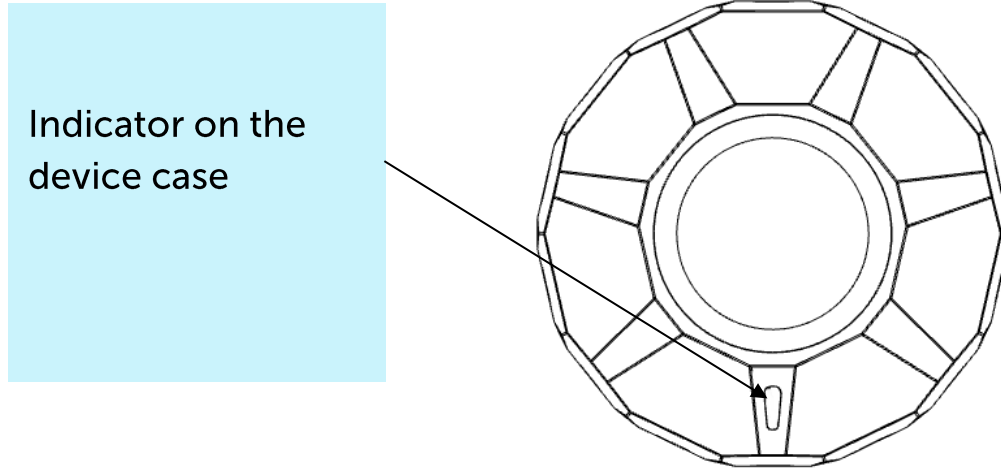

4 – LED indicator

5 –UART port

**INDICATION**

A double color indicator is located on the front of the sensor case.



LED SIGNAL		MEANING
	One long red flashing	The device connected to the network and is in active mode
	Three long flashings	Linking to the network is unsuccessful
	One short green flashing in 30 seconds	"Waiting" (01) state
	Two long green flashings in a row	Switching to the "Waiting" state
	Series of short red flashings	"Alarm sending" (02) state Linking to the network
	One short 0.5 s red flashing in 2 seconds	"Alarm received" (03) state
	Two short green flashings in a row	Sending a message in the "Alarm cancellation" (04) state
	Red glowing	"Alarm accepted by operator" (05) state
	One short red flashing in 30 seconds	Battery charge less than or equal to 10%

## BUTTON MOUNTING RECOMMENDATIONS

To provide the stable radio between the gateway and the end device it is recommended avoiding the device installation in the places which are barriers for the radio signal getting through like a reinforced floors and walls, a basement, an underground facilities and wells, a metal case etc.

The necessary stage for the network deploying including a big quantity of end devices is a radio planning work with nature experiments.

The button must be installed in such a way that the User can quickly press it in the alarm event.

Do not install the button near objects that are powerful sources of heat or having the ability to change their temperature quickly (fireplaces, stoves, air conditioners, radiators, etc.), in places with strong air currents or the possibility of direct sunlight.

The wall on which the sensor is mounted should not be subjected to strong vibrations. The button should be installed on the flat and smooth surface in order to obtain tight connection.

It is not recommended to block the User's access to the button.



**Before starting mounting work, you must make sure that the latest firmware version is installed on the device**

For mounting you will need:

- ⦿ laptop;
- ⦿ Vega USB-UART converter or Vega FSK Dongle



**Initially, the device is not connected to power because no batteries are installed**

Step by step mounting guide:

1. Setting the devices and connecting them to the network are usually carried out in the office (see Network Deployment Manual).
2. Determination of suitable places for mounting at the object with a network tester.
3. Install the batteries. To do this, unscrew the back cover of the device and place AAA batteries in the appropriate slots, observing the polarity.

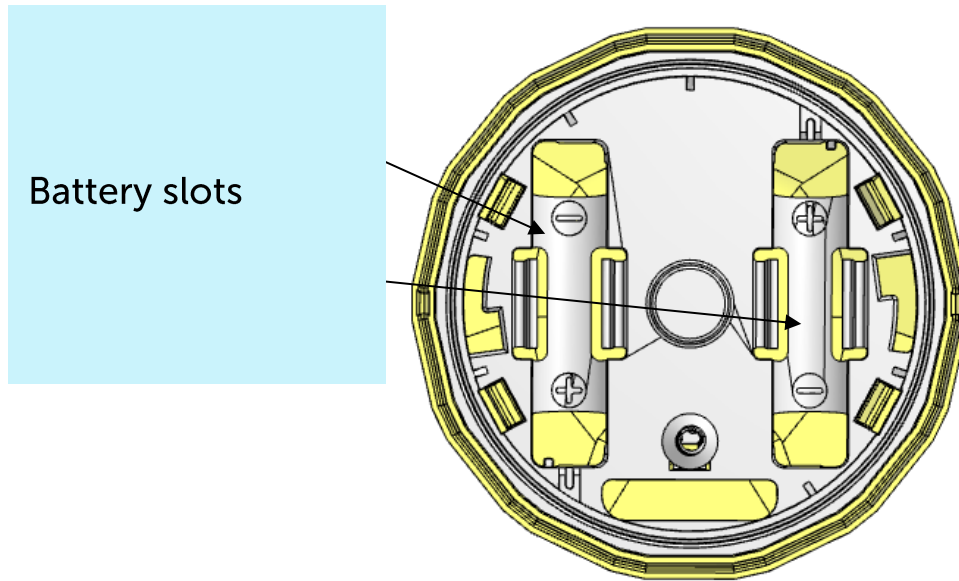

4. Starting the device - switching to the "Active" mode and registration on the network will occur after installing the battery or pressing the button.



If all attempts fail, the device will continue to accumulate data and will attempt to connect to the network every 6 hours or until the button will be pressed.

5. Assembling the device.
6. Installation of the button on the object.
7. By the laptop you can make sure that the device successfully sends the data.

## 4 COMMUNICATION PROTOCOL – 2.0 VERSION

This part describes the Smart-WB0101 communication protocol with LoRaWAN® network.



**In fields consisting of several bytes, the little-endian byte order is used**

### SMART-WB0101 TRANSMITS THE FOLLOWING TYPES OF PACKETS

1. Packet with operation modes of the button information transmitting on LoRaWAN® port 2

Size in bytes	Field description	Data type
1 byte	Operating modes of the button 01 –Waiting 02 - Alarm transmission 03 - Alarm received by Server 04 - Alarm cancellation 05 - Alarm accepted by the Operator 06 - Press. idle mode enabled	uint8
1 byte	Battery charge, %	uint8
4 bytes	Time of forming this packet (unixtime UTC)	uint32
1 byte	Temperature in °C	uint8

2. Settings packet – transmitting on LoRaWAN® port 3 when settings request command received, or device connected to the network

Size in bytes	Field description	Data type
1 byte	Packet type, this packet == 0	uint8
2 bytes	ID of parameter	uint16
1 byte	Data length (len)	uint8
len byte	Parameter value	-----
2 bytes	ID of parameter	uint16
1 byte	Data length (len)	uint8
len byte	Parameter value	-----
...	...	...
2 bytes	ID of parameter	uint16
1 byte	Data length (len)	uint8
len byte	Parameter value	-----

## SMART-WB0101 RECEIVES THE FOLLOWING TYPES OF PACKETS

1. Packet with request of settings (standard) – sent by application on LoRaWAN® port 3

Size in bytes	Field description	Data type
1 byte	Packet type, this packet == 01	uint8

Answering that packet, the device sends the packet with settings.

2. Packet with settings is identical to such packet from device transmitting to LoRaWAN® port 3

Size in bytes	Field description	Data type
1 byte	Packet type, this packet == 0	uint8
2 bytes	ID of parameter	uint16
1 byte	Data length (len)	uint8
len byte	Parameter value	-----
2 bytes	ID of parameter	uint16
1 byte	Data length (len)	uint8
len byte	Parameter value	-----
...	...	...
2 bytes	ID of parameter	uint16
1 byte	Data length (len)	uint8
len byte	Parameter value	-----

The package with settings sent to the device may not contain all the settings supported by the device, but only the part that needs to be changed.

Table of ID of Smart-WB0101 parameters and these possible values



The table contains values in DEC, when sending, these values must be converted to HEX

ID of parameter	Description	Data length	Possible values
4	Confirmed uplinks	1 byte	1 – confirmed 2 – unconfirmed
8	Uplinks number of transmissions	1 byte	from 1 to 15

16	Communication period	1 byte	1 – 1 hour 2 – 6 hours 3 – 12 hours 4 – 24 hours 5 – 5 minutes 6 – 15 minutes 7 – 30 minutes
48	Time to determine a long press on the button, s	1 byte	from 0 to 25 seconds
49	Data collection period	1 byte	1 – 1 hour 2 – 6 hours 3 – 12 hours 4 – 24 hours 5 – 5 minutes 6 – 15 minutes 7 – 30 minutes
55	Time zone, in minutes	2 bytes	from -720 to 840
78	Period of sending messages in alarm mode in seconds	1 byte	from 1 to 99
127	Disabling the alarm by holding the button down for a long time	1 byte	1 - on 0 - off
305	Notification mode	1 byte	1 - simple 0 - with acknowledgment

3. Package switches state to "Alarm received by Server" – sent by application on LoRaWAN® port 2

Size in bytes	Field description	Data type
1 byte	Packet type, this packet == 03	uint8

4. Package switches state to "Waiting" from "Alarm cancellation" – sent by application on LoRaWAN® port 2

Size in bytes	Field description	Data type
1 byte	Packet type, this packet == 04	uint8

5. Package switches state to "Alarm accepted by the Operator" – sent by application on LoRaWAN® port 2

Size in bytes	Field description	Data type
1 byte	Packet type, this packet == 05	uint8

6. Package switches state to "Waiting" – sent by application on LoRaWAN® port 2

Size in bytes	Field description	Data type
1 byte	Packet type, this packet == 06	uint8

## 5 STORAGE AND TRANSPORTATION REQUIREMENTS

The Smart-WB0101 button shall be stored in the original packaging in heated room at temperatures +5 °C to +40 °C and relative humidity less than 85%.

The sensor shall be transported in covered freight compartments of all types at any distance at temperatures -40 °C to +70 °C.

## 6 CONTENT OF THE PACKAGE

Smart-WB0101 button is delivered complete with:

Vega Smart-WB0101 button – 1 pc.

AAA battery – 2 pcs.

Factory certificate – 1 pc.

## 7 WARRANTY

The manufacturer guarantees that the product complies with the current technical documentation, subject to the storage, transportation and operation conditions specified in the "User Manual".

The warranty period is 36 months. The warranty does not cover batteries.

The warranty period of operation is calculated from the date of sale marked in the product factory certificate, and from the release date when such a mark is absent. During the warranty period, the manufacturer is obliged to provide repair services or replace a failed device or its components.

The manufacturer does not bear warranty obligations in the event of a product failure if:

- ⦿ the product does not have a factory certificate;
- ⦿ the factory certificate does not have an TCD stamp and / or there is no sticker with information about the device;
- ⦿ the serial number (DevEUI, EMEI) printed on the product differs from the serial number (DevEUI, EMEI) specified in the factory certificate;
- ⦿ the product has been subject to alterations in the design and / or software which are not provided for in the operational documentation;
- ⦿ the product has mechanical, electrical and / or other damage and defects arising from violation of the conditions of transportation, storage and operation;
- ⦿ the product has traces of repair outside the manufacturer's service center;
- ⦿ the components of the product have internal damage caused by the ingress of foreign objects / liquids and / or natural disasters (flood, fire, etc.).

The average service life of the product is 5 years.

In the event of a warranty claim, contact the service center:

119A, Bol'shevistskaya Str., Novosibirsk, 630009, Russia.

Tel.: +7 (383) 206-41-35.

e-mail: [remont@vega-absolute.ru](mailto:remont@vega-absolute.ru)

DOCUMENT INFORMATION	
Title	Smart-WB0101 LoRaWAN® button
Document type	Manual – Translation from Russian
Document number	V05-WB0101-01
Revision and date	03 – 08 May 2026

### Revision History

Revision	Date	Name	Comments
01	13.07.2022	KMA	Document creation date
02	16.02.2023	KMA	Minor edits
03	08.05.2026	NEE	The enclosure protection rating has been updated to IP20. The "Idle" state has been added to the following sections: " <a href="#">Operation Algorithm</a> ", " <a href="#">SMART-WB0101 transmits the following types of packets</a> ", and " <a href="#">SMART-WB0101 receives the following types of packets</a> ".



[vega-absolute.ru](http://vega-absolute.ru)

Operation Manual © Vega-Absolute OOO 2026